

LQW15AN2N2D80#

indicates a package specification code.



< List of part numbers with package codes >
 LQW15AN2N2D80D , LQW15AN2N2D80B

Shape

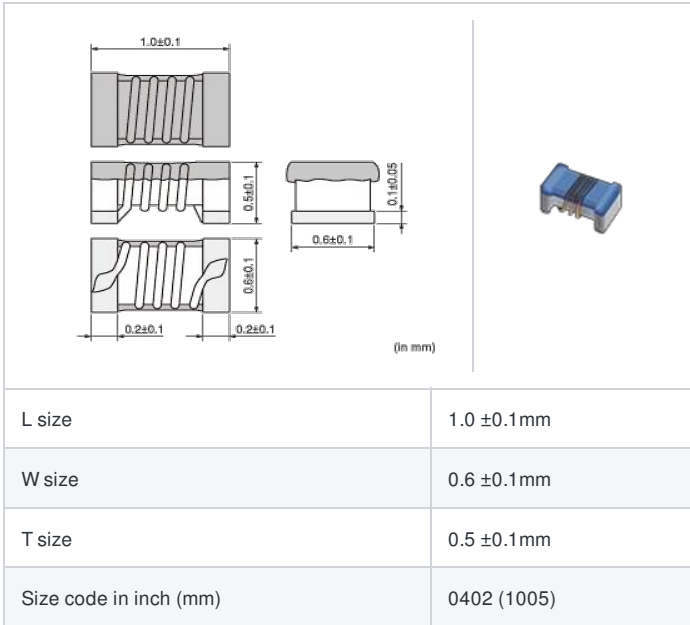

Notes

In operating temperatures exceeding +85°C, derating of current is necessary for the LQW15A_80 series.
 Please apply the derating curve shown in the chart according to the operating temperature.
 Please consider "Notice (Rating)."

References

Packaging code	Specifications	Minimum quantity
D	φ 180mm Paper taping	10000
B	Packing in bulk	500

Mass (Typ.)	
1 piece	0.0009g

Specifications

Inductance	2.2nH ±0.5nH
Inductance test frequency	100MHz
Rated current (Itemp) (Based on Temperature rise)	2530mA
Max. of DC resistance	0.022Ω
Q (min.)	30
Q test frequency	250MHz
Self resonance frequency (min.)	15.5GHz
Operating temperature range (Self-temperature rise is not included)	-55~125°C
Series	LQW15AN_80

Attention

- 1.This datasheet is downloaded from the website of Murata Manufacturing Co., Ltd. Therefore, it's specifications are subject to change or our products in it may be discontinued without advance notice. Please check with our sales representatives or product engineers before ordering.
- 2.This datasheet has only typical specifications because there is no space for detailed specifications. Therefore, please review our product specifications or consult the approval sheet for product specifications before ordering.

In operating temperatures exceeding +85°C, derating of current is necessary for this series.
Please apply the derating curve shown in the chart according to the operating temperature.

Derating of Rated Current

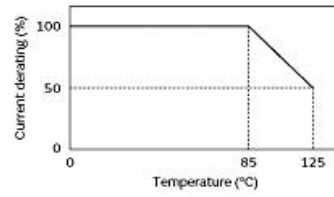

 **Attention**

- 1.This datasheet is downloaded from the website of Murata Manufacturing Co., Ltd. Therefore, it's specifications are subject to change or our products in it may be discontinued without advance notice. Please check with our sales representatives or product engineers before ordering.
 - 2.This datasheet has only typical specifications because there is no space for detailed specifications.
- Therefore, please review our product specifications or consult the approval sheet for product specifications before ordering.

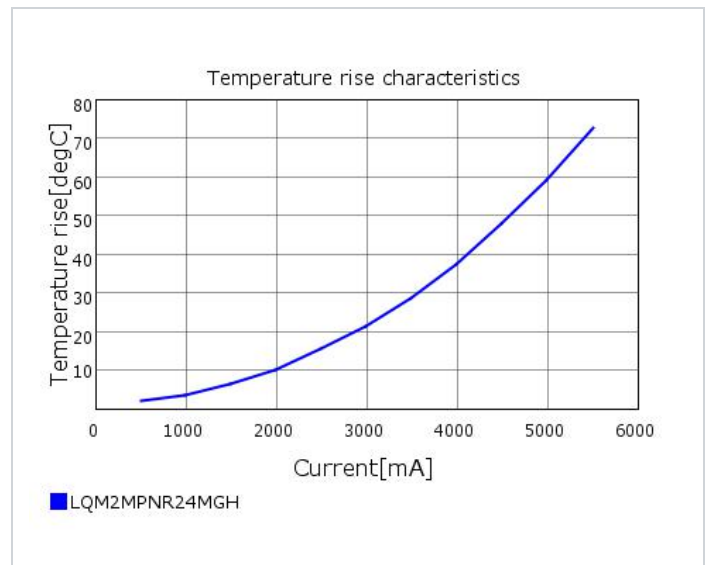
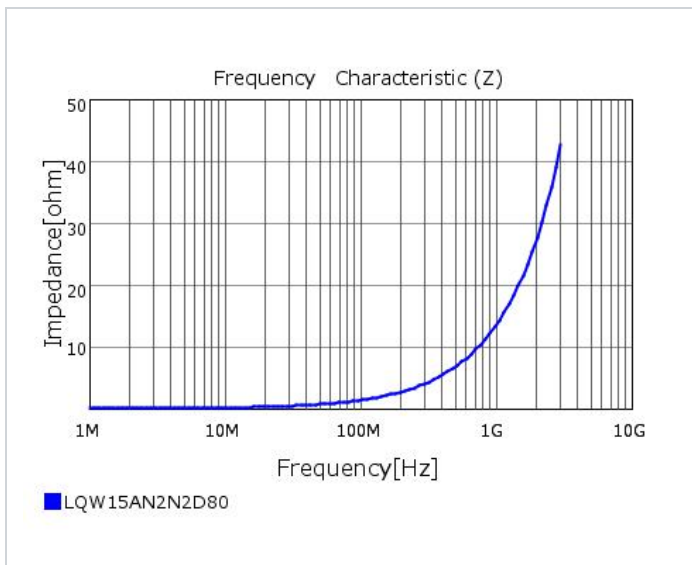
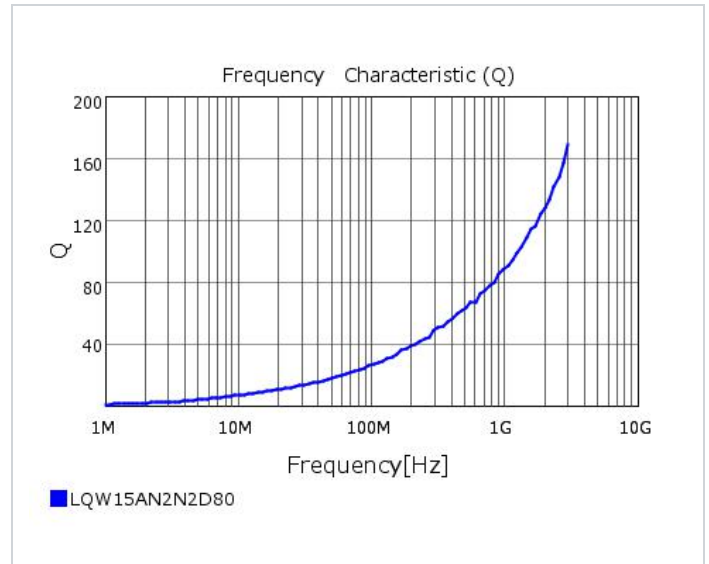
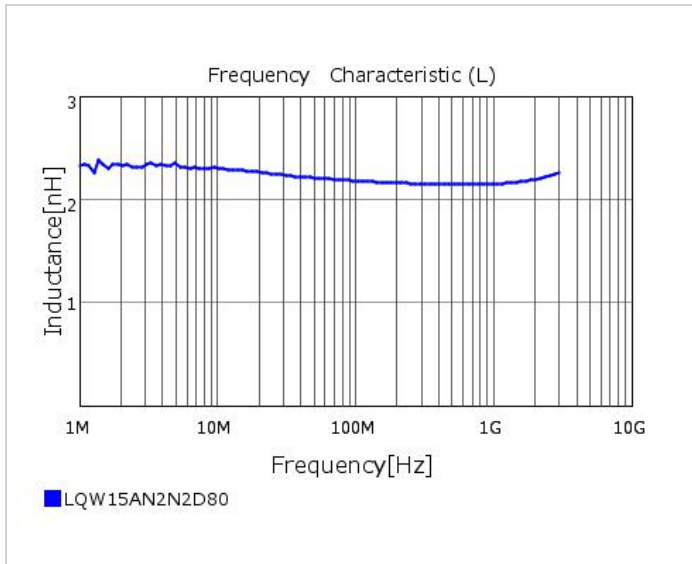

⚠ Attention

- 1.This datasheet is downloaded from the website of Murata Manufacturing Co., Ltd. Therefore, it's specifications are subject to change or our products in it may be discontinued without advance notice. Please check with our sales representatives or product engineers before ordering.
- 2.This datasheet has only typical specifications because there is no space for detailed specifications. Therefore, please review our product specifications or consult the approval sheet for product specifications before ordering.